

DATA SHEET

CGY2030M **DECT 500 mW power amplifier**

Product specification
Supersedes data of 1996 Jul 12
File under Integrated Circuits, IC17

1997 Jan 17

DECT 500 mW power amplifier

CGY2030M

FEATURES

- Power Amplifier (PA) overall efficiency 40%
- 27 dB gain
- 0 dBm input power
- Operation possible without negative supply
- Wide operating temperature range -30 to +85 °C
- SSOP16 package.

GENERAL DESCRIPTION

The CGY2030M is a GaAs Monolithic Microwave Integrated Circuit (MMIC) power amplifier specifically designed to operate at 3.6 V battery supply. When power control is not required, it can be operated without negative supply voltage.

APPLICATIONS

- 1.88 to 1.9 GHz transceivers for DECT applications
- 2 GHz transceivers (PHS, DCS).

QUICK REFERENCE DATA

SYMBOL	PARAMETER ⁽¹⁾	MIN.	TYP.	MAX.	UNIT
V _{DD}	positive supply voltage	-	3.2	-	V
I _{DD}	positive peak supply current	-	400	-	mA
P _o	output power	-	27	-	dBm
T _{amb}	operating ambient temperature	-30	-	+85	°C

Note

1. For conditions, see Chapters "AC characteristics" and "DC characteristics".

ORDERING INFORMATION

TYPE NUMBER	PACKAGE		
	NAME	DESCRIPTION	VERSION
CGY2030M	SSOP16	plastic shrink small outline package; 16 leads; body width 4.4 mm	SOT369-1

BLOCK DIAGRAM

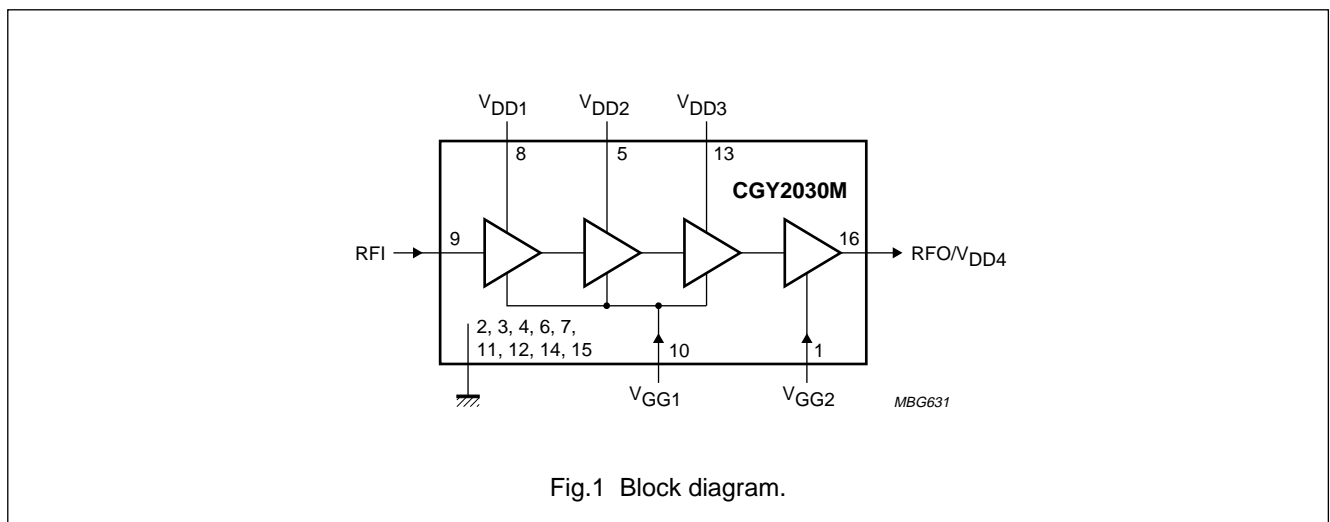

DECT 500 mW power amplifier

CGY2030M

PINNING

SYMBOL	PIN	DESCRIPTION
V _{GG2}	1	fourth stage negative gate supply voltage
GND	2 to 4	ground
V _{DD2}	5	second stage supply voltage
GND	6 and 7	ground
V _{DD1}	8	first stage supply voltage
RFI	9	PA input
V _{GG1}	10	first second and third stages negative gate supply voltage
GND	11 and 12	ground
V _{DD3}	13	third stage supply voltage
GND	14 and 15	ground
RFO/V _{DD4}	16	PA output and fourth stage supply voltage

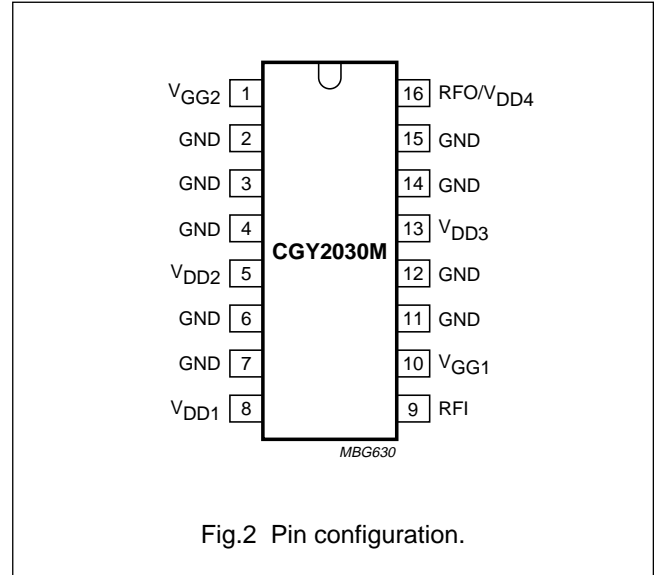

Fig.2 Pin configuration.

FUNCTIONAL DESCRIPTION

Amplifier

The CGY2030M is a 4-stage GaAs MESFET power amplifier capable of delivering 500 mW (typ.) at 1.9 GHz into a 50 Ω load. Each amplifier stage has an open-drain configuration. The drains have to be loaded externally by adequate reactive circuits which must also provide a DC path to the supply.

The amplifier can be switched off by means of an external PNP series switch connected between the battery and the amplifier drains. This switch can also be used to vary the actual supply voltage applied to the amplifier and hence, control the output power.

This device is specifically designed to work with a maximum duty factor of 25%.

Biasing

Two modes of operation are possible:

- Mode 1
- Mode 2.

MODE 1

In the first mode, the pins V_{GG1} and V_{GG2} are simply connected together to the ground via resistors (10 kΩ in the evaluation board; see Fig.4). The amplifier biases itself internally to a negative voltage by action of the incoming RF signal. In this mode, power control cannot be achieved by varying the amplifier supply voltage; therefore it is suitable only for applications where power control is not required such as DECT.

MODE 2

If a negative bias is available, a second mode of operation is possible, in which the amplifier is biased by providing adequate negative voltages at pins V_{GG1} and V_{GG2}. In this mode, the amplifier internal bias does not depend on the incoming RF level, nor on the drain voltage, so that power control is possible by variation of the supply voltage.

DECT 500 mW power amplifier

CGY2030M

LIMITING VALUES

In accordance with the Absolute Maximum Rating System (IEC 134).

SYMBOL	PARAMETER	CONDITIONS	MIN.	TYP.	MAX.	UNIT
V_{DD}	operating supply voltage		–	–	5.2	V
$V_{DD} - V_{GG}$	voltage difference between supply voltage and gate bias voltage	no input signal	–	–	8	V
$T_{j(max)}$	maximum operating junction temperature		–	–	150	°C
P_{tot}	total power dissipation		–	–	400	mW
T_{stg}	IC storage temperature		–55	–	+125	°C

THERMAL CHARACTERISTICS

SYMBOL	PARAMETER	VALUE	UNIT
$R_{th\ j-a}$	thermal resistance from junction to ambient in free air	145	K/W

HANDLING

Do not operate or store near strong electrostatic fields. Meets class 1 ESD test requirements [Human Body Model (HBM)], in accordance with "MIL STD 883C - method 3015".

DC CHARACTERISTICS

$V_{DD} = 3.2\text{ V}$; $T_{amb} = 25\text{ °C}$; unless otherwise specified.

SYMBOL	PARAMETER	CONDITIONS	MIN.	TYP.	MAX.	UNIT
Pins RFO/V_{DD4}, V_{DD3}, V_{DD2} and V_{DD1}						
V_{DD}	positive supply voltage		2.6	3.2	4.2	V
I_{DD}	positive peak supply current		–	400	500	mA
Pins V_{GG1} and V_{GG2}; in mode 2						
V_{GG1}	bias voltage for input stages	note 1	–	–1.2	–	V
V_{GG2}	bias voltage for output stage	note 1	–	–2.0	–	V
$I_{GG(tot)}$	total gate peak current	note 2	–1	–	+1	mA

Notes

1. Negative voltages V_{GG1} and V_{GG2} must be applied before supply voltage V_{DD} .
2. Due to non linear effects at high power levels, the gate current can be either negative or positive.

DECT 500 mW power amplifier

CGY2030M

AC CHARACTERISTICS

$V_{DD} = 3.2\text{ V}$; $f_{RF} = 1900\text{ MHz}$; $P_i = 0\text{ dBm}$; $T_{amb} = 25\text{ }^\circ\text{C}$; duty factor $\delta = 25\%$; $50\text{ }\Omega$ impedance system; measured and guaranteed on CGY2030M evaluation board (see Fig.4).

SYMBOL	PARAMETER	CONDITIONS	MIN.	TYP.	MAX.	UNIT
P_i	input power	note 1	-3	-	+5	dBm
δ	duty factor		-	-	25	%
f_{RF}	operating frequency		-	1900	-	MHz
Measured in mode 1; without negative biasing; V_{GG1} and V_{GG2} connected to ground						
P_o	output power		26	27	28.5	dBm
η	efficiency		-	40	-	%
P_{leak}	RF leakage to output in power off state	$V_{DD} = 0\text{ V}$	-	-40	-	dBm
H2, H3	second and third harmonics level		-	-35	-	dBc
Stab	stability (spurious levels)	note 2	-	-60	-	dBc
Measured in mode 2; with negative biasing at pins V_{GG1} and V_{GG2}						
P_o	output power		25.5	26.5	28	dBm
η	efficiency		-	35	-	%
P_{leak}	RF leakage to output in power off state	$V_{DD} = 0\text{ V}$	-	-50	-	dBm

Notes

1. Self biasing guaranteed in mode 1 at minimum input power (-3 dBm) and minimum supply voltage V_{DD} (2.6 V).
2. The device is adjusted to provide nominal value of load power into a $50\text{ }\Omega$ load. The device is switched off and a 6 : 1 load replaces the $50\text{ }\Omega$ load. The device is switched on and the phase of the 6 : 1 load is varied 360 electrical degrees during a 60 seconds test period.

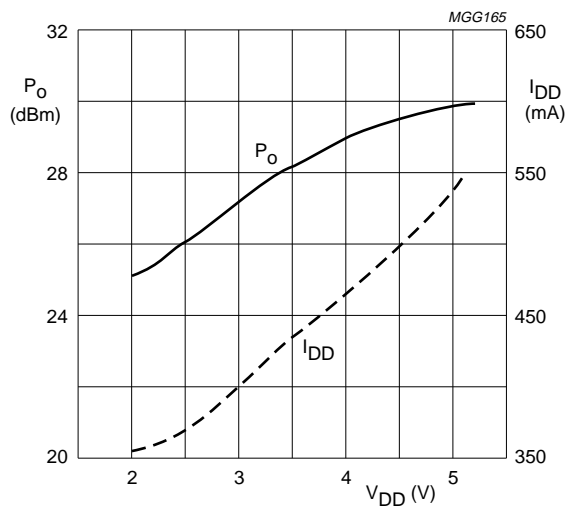

Fig.3 Typical power and current characteristics in mode 1.

DECT 500 mW power amplifier

CGY2030M

APPLICATION INFORMATION

The CGY2030M is operated and tested in accordance with the circuit diagram shown in Fig.4. Supply voltage switching is achieved by two bipolar PNP transistors. One transistor switches the first and second stages and the other switches the third and fourth stages.

By switching on the last amplifier stages with some delay compared to the first stages, it is possible to get the last stages already self-biased before their supply voltage has reached its steady state value. This enables smooth power up-ramping without any power overshoot. A simpler drain switching circuit can be used if the amplifier is operated with negative biasing of the pins V_{GG1} and V_{GG2} .

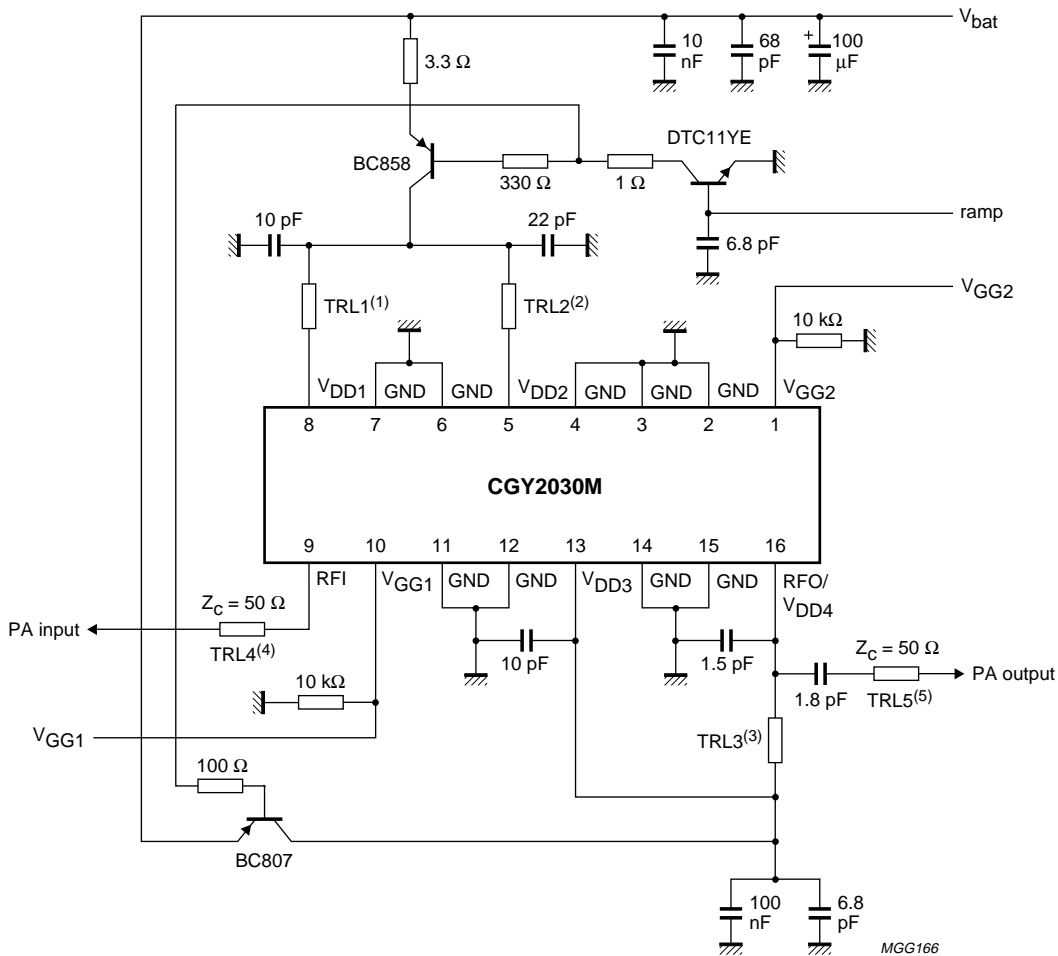

Thickness: 0.8 mm; substrate: FR4; $\epsilon_r = 4.7$.

- (1) TRL1: width = 500 μm ; length = 11200 μm .
- (2) TRL2: width = 500 μm ; length = 7770 μm .
- (3) TRL3: width = 300 μm ; length = 15450 μm .
- (4) TRL4: width = 1600 μm ; length = 12000 μm .
- (5) TRL5: width = 1600 μm ; length = 11000 μm .

Fig.4 Evaluation board schematic.

DECT 500 mW power amplifier

CGY2030M

PACKAGE OUTLINE

SSOP16: plastic shrink small outline package; 16 leads; body width 4.4 mm

SOT369-1

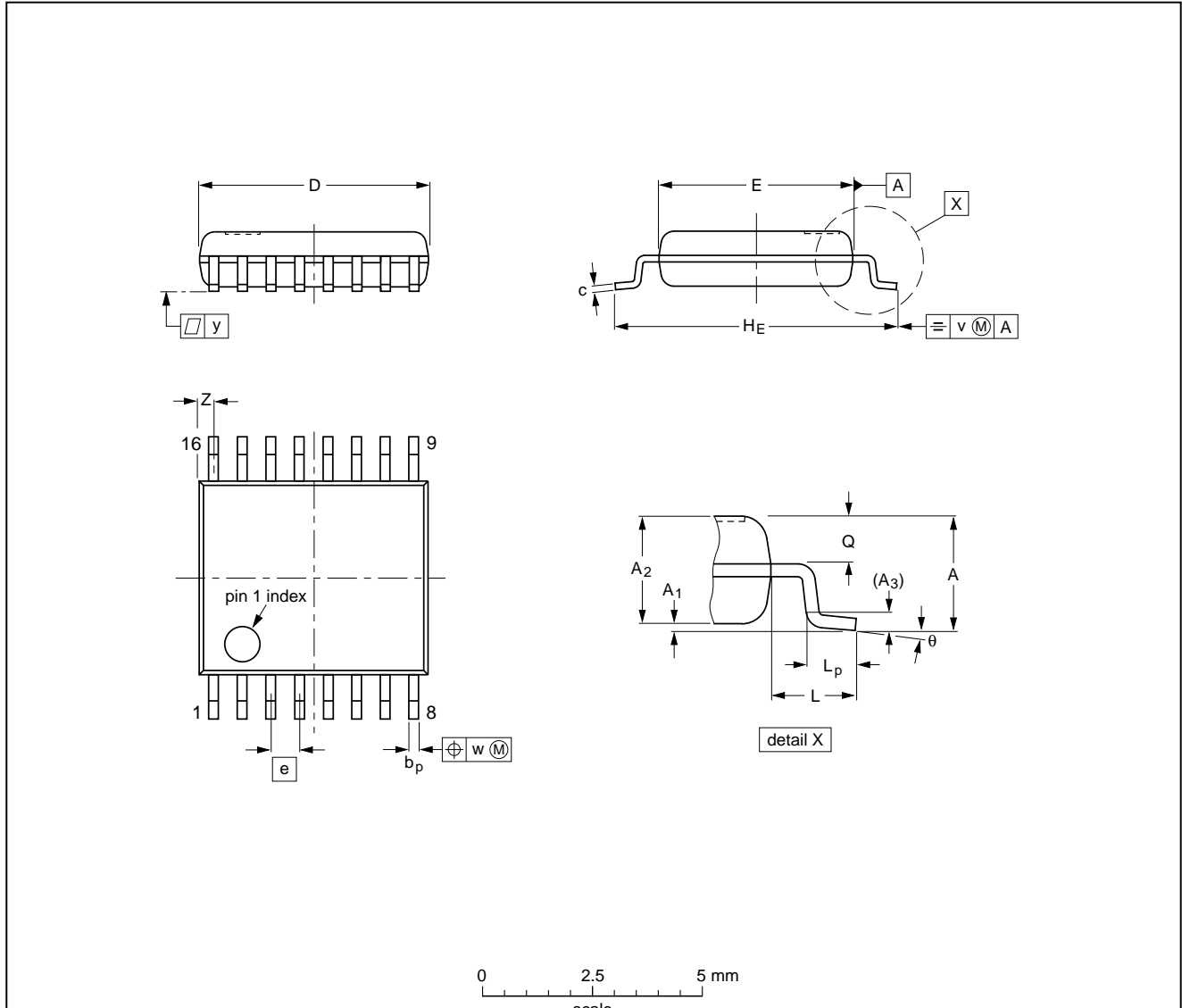

DIMENSIONS (mm are the original dimensions)

UNIT	A max.	A ₁	A ₂	A ₃	b _p	c	D ⁽¹⁾	E ⁽¹⁾	e	H _E	L	L _p	Q	v	w	y	Z ⁽¹⁾	θ
mm	1.5	0.15 0.00	1.4 1.2	0.25	0.32 0.20	0.25 0.13	5.30 5.10	4.5 4.3	0.65	6.6 6.2	1.0	0.75 0.45	0.65 0.45	0.2	0.13	0.1	0.48 0.18	10° 0°

Note

1. Plastic or metal protrusions of 0.20 mm maximum per side are not included.

OUTLINE VERSION	REFERENCES				EUROPEAN PROJECTION	ISSUE DATE
	IEC	JEDEC	EIAJ			
SOT369-1						94-04-20 95-02-04

DECT 500 mW power amplifier

CGY2030M

SOLDERING

Introduction

There is no soldering method that is ideal for all IC packages. Wave soldering is often preferred when through-hole and surface mounted components are mixed on one printed-circuit board. However, wave soldering is not always suitable for surface mounted ICs, or for printed-circuits with high population densities. In these situations reflow soldering is often used.

This text gives a very brief insight to a complex technology. A more in-depth account of soldering ICs can be found in our *"IC Package Databook"* (order code 9398 652 90011).

Reflow soldering

Reflow soldering techniques are suitable for all SSOP packages.

Reflow soldering requires solder paste (a suspension of fine solder particles, flux and binding agent) to be applied to the printed-circuit board by screen printing, stencilling or pressure-syringe dispensing before package placement.

Several techniques exist for reflowing; for example, thermal conduction by heated belt. Dwell times vary between 50 and 300 seconds depending on heating method. Typical reflow temperatures range from 215 to 250 °C.

Preheating is necessary to dry the paste and evaporate the binding agent. Preheating duration: 45 minutes at 45 °C.

Wave soldering

Wave soldering is **not** recommended for SSOP packages. This is because of the likelihood of solder bridging due to closely-spaced leads and the possibility of incomplete solder penetration in multi-lead devices.

If wave soldering cannot be avoided, the following conditions must be observed:

- **A double-wave (a turbulent wave with high upward pressure followed by a smooth laminar wave) soldering technique should be used.**
- **The longitudinal axis of the package footprint must be parallel to the solder flow and must incorporate solder thieves at the downstream end.**

Even with these conditions, only consider wave soldering SSOP packages that have a body width of 4.4 mm, that is SSOP16 (SOT369-1) or SSOP20 (SOT266-1).

During placement and before soldering, the package must be fixed with a droplet of adhesive. The adhesive can be applied by screen printing, pin transfer or syringe dispensing. The package can be soldered after the adhesive is cured.

Maximum permissible solder temperature is 260 °C, and maximum duration of package immersion in solder is 10 seconds, if cooled to less than 150 °C within 6 seconds. Typical dwell time is 4 seconds at 250 °C.

A mildly-activated flux will eliminate the need for removal of corrosive residues in most applications.

Repairing soldered joints

Fix the component by first soldering two diagonally-opposite end leads. Use only a low voltage soldering iron (less than 24 V) applied to the flat part of the lead. Contact time must be limited to 10 seconds at up to 300 °C. When using a dedicated tool, all other leads can be soldered in one operation within 2 to 5 seconds between 270 and 320 °C.

DECT 500 mW power amplifier

CGY2030M

DEFINITIONS

Data sheet status	
Objective specification	This data sheet contains target or goal specifications for product development.
Preliminary specification	This data sheet contains preliminary data; supplementary data may be published later.
Product specification	This data sheet contains final product specifications.
Limiting values	
Limiting values given are in accordance with the Absolute Maximum Rating System (IEC 134). Stress above one or more of the limiting values may cause permanent damage to the device. These are stress ratings only and operation of the device at these or at any other conditions above those given in the Characteristics sections of the specification is not implied. Exposure to limiting values for extended periods may affect device reliability.	
Application information	
Where application information is given, it is advisory and does not form part of the specification.	

LIFE SUPPORT APPLICATIONS

These products are not designed for use in life support appliances, devices, or systems where malfunction of these products can reasonably be expected to result in personal injury. Philips customers using or selling these products for use in such applications do so at their own risk and agree to fully indemnify Philips for any damages resulting from such improper use or sale.

DECT 500 mW power amplifier

CGY2030M

NOTES

DECT 500 mW power amplifier

CGY2030M

NOTES

Philips Semiconductors – a worldwide company

Argentina: see South America

Australia: 34 Waterloo Road, NORTH RYDE, NSW 2113,
Tel. +61 2 9805 4455, Fax. +61 2 9805 4466

Austria: Computerstr. 6, A-1101 WIEN, P.O. Box 213,
Tel. +43 1 60 101, Fax. +43 1 60 101 1210

Belarus: Hotel Minsk Business Center, Bld. 3, r. 1211, Volodarski Str. 6,
220050 MINSK, Tel. +375 172 200 733, Fax. +375 172 200 773

Belgium: see The Netherlands

Brazil: see South America

Bulgaria: Philips Bulgaria Ltd., Energoproject, 15th floor,
51 James Bourchier Blvd., 1407 SOFIA,
Tel. +359 2 689 211, Fax. +359 2 689 102

Canada: PHILIPS SEMICONDUCTORS/COMPONENTS,
Tel. +1 800 234 7381

China/Hong Kong: 501 Hong Kong Industrial Technology Centre,
72 Tat Chee Avenue, Kowloon Tong, HONG KONG,
Tel. +852 2319 7888, Fax. +852 2319 7700

Colombia: see South America

Czech Republic: see Austria

Denmark: Prags Boulevard 80, PB 1919, DK-2300 COPENHAGEN S,
Tel. +45 32 88 2636, Fax. +45 31 57 1949

Finland: Sinikalliontie 3, FIN-02630 ESPOO,
Tel. +358 9 615800, Fax. +358 9 61580/xxx

France: 4 Rue du Port-aux-Vins, BP317, 92156 SURESNES Cedex,
Tel. +33 1 40 99 6161, Fax. +33 1 40 99 6427

Germany: Hammerbrookstraße 69, D-20097 HAMBURG,
Tel. +49 40 23 53 60, Fax. +49 40 23 536 300

Greece: No. 15, 25th March Street, GR 17778 TAVROS/ATHENS,
Tel. +30 1 4894 339/239, Fax. +30 1 4814 240

Hungary: see Austria

India: Philips INDIA Ltd, Shivsagar Estate, A Block, Dr. Annie Besant Rd.
Worli, MUMBAI 400 018, Tel. +91 22 4938 541, Fax. +91 22 4938 722

Indonesia: see Singapore

Ireland: Newstead, Clonskeagh, DUBLIN 14,
Tel. +353 1 7640 000, Fax. +353 1 7640 200

Israel: RAPAC Electronics, 7 Kehilat Saloniki St, TEL AVIV 61180,
Tel. +972 3 645 0444, Fax. +972 3 649 1007

Italy: PHILIPS SEMICONDUCTORS, Piazza IV Novembre 3,
20124 MILANO, Tel. +39 2 6752 2531, Fax. +39 2 6752 2557

Japan: Philips Bldg 13-37, Kohnan 2-chome, Minato-ku, TOKYO 108,
Tel. +81 3 3740 5130, Fax. +81 3 3740 5077

Korea: Philips House, 260-199 Itaewon-dong, Yongsan-ku, SEOUL,
Tel. +82 2 709 1412, Fax. +82 2 709 1415

Malaysia: No. 76 Jalan Universiti, 46200 PETALING JAYA, SELANGOR,
Tel. +60 3 750 5214, Fax. +60 3 757 4880

Mexico: 5900 Gateway East, Suite 200, EL PASO, TEXAS 79905,
Tel. +9-5 800 234 7381

Middle East: see Italy

Netherlands: Postbus 90050, 5600 PB EINDHOVEN, Bldg. VB,
Tel. +31 40 27 82785, Fax. +31 40 27 88399

New Zealand: 2 Wagener Place, C.P.O. Box 1041, AUCKLAND,
Tel. +64 9 849 4160, Fax. +64 9 849 7811

Norway: Box 1, Manglerud 0612, OSLO,
Tel. +47 22 74 8000, Fax. +47 22 74 8341

Philippines: Philips Semiconductors Philippines Inc.,
106 Valero St. Salcedo Village, P.O. Box 2108 MCC, MAKATI,
Metro MANILA, Tel. +63 2 816 6380, Fax. +63 2 817 3474

Poland: Ul. Lukiska 10, PL 04-123 WARSZAWA,
Tel. +48 22 612 2831, Fax. +48 22 612 2327

Portugal: see Spain

Romania: see Italy

Russia: Philips Russia, Ul. Usatcheva 35A, 119048 MOSCOW,
Tel. +7 095 755 6918, Fax. +7 095 755 6919

Singapore: Lorong 1, Toa Payoh, SINGAPORE 1231,
Tel. +65 350 2538, Fax. +65 251 6500

Slovakia: see Austria

Slovenia: see Italy

South Africa: S.A. PHILIPS Pty Ltd., 195-215 Main Road Martindale,
2092 JOHANNESBURG, P.O. Box 7430 Johannesburg 2000,
Tel. +27 11 470 5911, Fax. +27 11 470 5494

South America: Rua do Rocio 220, 5th floor, Suite 51,
04552-903 São Paulo, SÃO PAULO - SP, Brazil,
Tel. +55 11 821 2333, Fax. +55 11 829 1849

Spain: Balmes 22, 08007 BARCELONA,
Tel. +34 3 301 6312, Fax. +34 3 301 4107

Sweden: Kottbygatan 7, Akalla, S-16485 STOCKHOLM,
Tel. +46 8 632 2000, Fax. +46 8 632 2745

Switzerland: Allmendstrasse 140, CH-8027 ZÜRICH,
Tel. +41 1 488 2686, Fax. +41 1 481 7730

Taiwan: Philips Semiconductors, 6F, No. 96, Chien Kuo N. Rd., Sec. 1,
TAIPEI, Taiwan Tel. +886 2 2134 2870, Fax. +886 2 2134 2874

Thailand: PHILIPS ELECTRONICS (THAILAND) Ltd.,
209/2 Sanpavuth-Bangna Road Prakanong, BANGKOK 10260,
Tel. +66 2 745 4090, Fax. +66 2 398 0793

Turkey: Talatpasa Cad. No. 5, 80640 GÜLTEPE/ISTANBUL,
Tel. +90 212 279 2770, Fax. +90 212 282 6707

Ukraine: PHILIPS UKRAINE, 4 Patrice Lumumba str., Building B, Floor 7,
252042 KIEV, Tel. +380 44 264 2776, Fax. +380 44 268 0461

United Kingdom: Philips Semiconductors Ltd., 276 Bath Road, Hayes,
MIDDLESEX UB3 5BX, Tel. +44 181 730 5000, Fax. +44 181 754 8421

United States: 811 East Arques Avenue, SUNNYVALE, CA 94088-3409,
Tel. +1 800 234 7381

Uruguay: see South America

Vietnam: see Singapore

Yugoslavia: PHILIPS, Trg N. Pasica 5/v, 11000 BEOGRAD,
Tel. +381 11 625 344, Fax. +381 11 635 777

For all other countries apply to: Philips Semiconductors, Marketing & Sales Communications,
Building BE-p, P.O. Box 218, 5600 MD EINDHOVEN, The Netherlands, Fax. +31 40 27 24825

Internet: <http://www.semiconductors.philips.com>

© Philips Electronics N.V. 1997

SCA53

All rights are reserved. Reproduction in whole or in part is prohibited without the prior written consent of the copyright owner.

The information presented in this document does not form part of any quotation or contract, is believed to be accurate and reliable and may be changed without notice. No liability will be accepted by the publisher for any consequence of its use. Publication thereof does not convey nor imply any license under patent- or other industrial or intellectual property rights.

Printed in The Netherlands

437027/1200/03/pp12

Date of release: 1997 Jan 17

Document order number: 9397 750 01565

Let's make things better.

**Philips
Semiconductors**



PHILIPS